

Top View

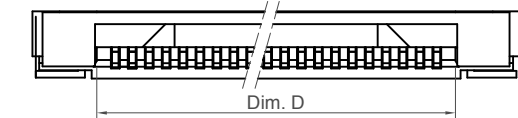

Front View

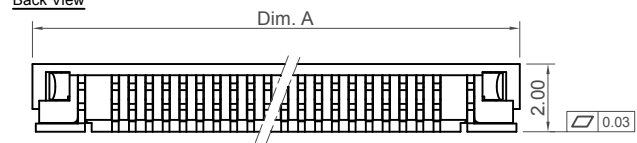

Back View

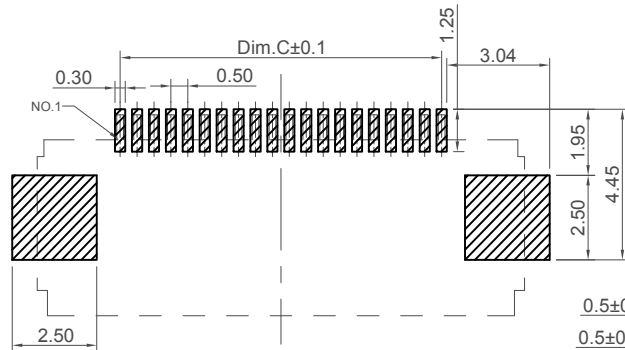

Recommended PCB Layout
as viewed from component side

▨ Solder Area □ Component Outline

Side Views

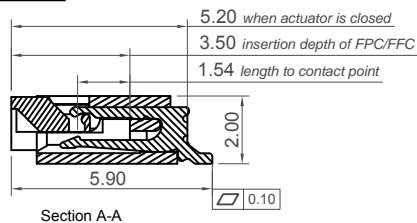

Section A-A

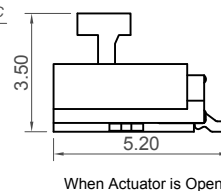

When Actuator is Open

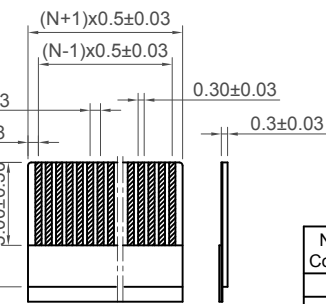

Recommended FFC/FPC
Dimensions
Thickness: 0.30±0.03

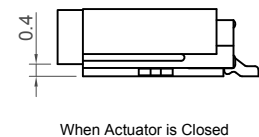

When Actuator is Closed

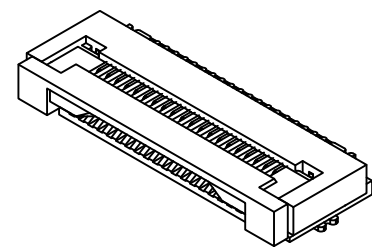

No. of Contacts	Dimensions			
	A	B	C	D
4	6.40	3.50	1.50	2.60
6	7.40	4.50	2.50	3.60
8	8.40	5.50	3.50	4.60
11	9.90	7.00	5.00	6.10
12	10.40	7.50	5.50	6.60
16	12.40	9.50	7.50	8.60
22	15.40	12.50	10.50	11.60
24	16.40	13.50	11.50	12.60
31	19.90	17.00	15.00	16.10
40	24.40	21.50	19.50	20.60
50	29.40	26.50	24.50	25.60
54	31.40	28.50	26.50	27.60

Specification:

Material:

- Housing Material: High-Temp Plastic LCP, UL 94V-0, White
- Actuator: LCP, UL 94V-0, Black
- Contact: Phosphor Bronze
- Finish (a) Contact Plating: see ordering grid
- (b) Underplating: Nickel-plated all over
- Fitting Nail: Brass, tin plated

Electrical:

- Voltage Rating (Max.): 50V AC/DC
- Current Rating (Max.): 0.4A AC/DC
- Dielectric Strength: 250V AC for 1 minute
between adjacent terminal, no breakdown
- Insulation Resistance: 50 MΩ Min. 250V DC
for 1 minute between adjacent terminal
- Contact Resistance: 40 mΩ Max.

Mechanical & Environmental

- Durability: 20 Cycles
- Operating Temperature: -25°C to +85°C
- Solder Profile: Peak Temp 260°C (+0/-5°C) Maximum (5 seconds)

Ordering Grid

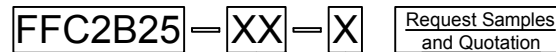

No. of Contacts

04 - 54

(see dimension table)

Contact Plating

T = Tin Plating over all (Standard)

(reel qty=2000pcs)

G = Gold Flash over all

(reel qty=2000pcs)

Part Number		Product Description	
FFC2B25		FPC 0.5mm Pitch Side Entry, Bottom Contact, SMT, Height=2.0mm, ZIF, Flip Lock Type	
Drawing Date		29th May 2010	
By	CC	Tolerances (Except as Noted)	Units:
Detail	FFC2B25 D PCN	Length X.X ± 0.30 X.XX ± 0.15 X.XXX ± 0.10	Metric (mm)
Revision	D1	Angle X.X° ± 2° X.XX° ± 1° X.XXX° ± 0.5°	3rd Angle Projection
Date	10/12/18		



This drawing is confidential and copyright of Global Connector Technology Ltd (GCT). This drawing must not be copied or disclosed without written consent. E & OE



Not to Scale	Drawn By PKN	Sheet No. 1/2
--------------	--------------	---------------

H
G
F
E
D
C
B
A

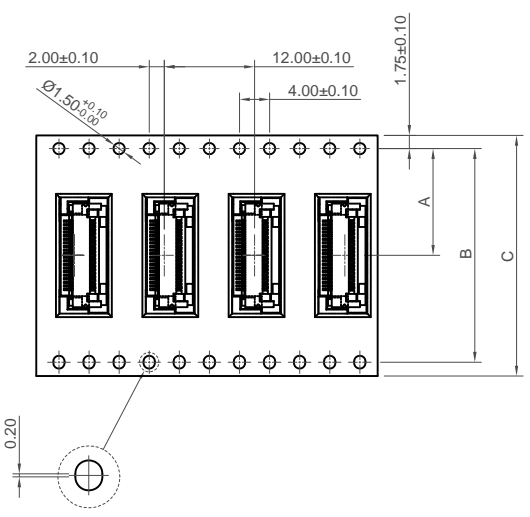
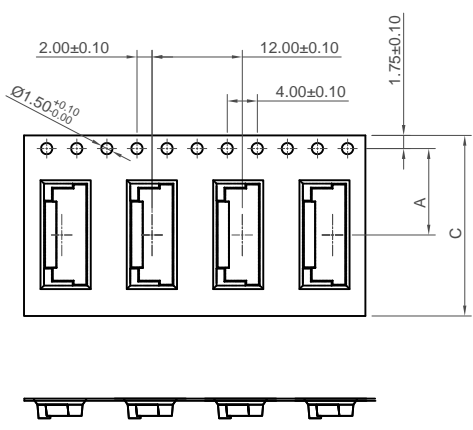
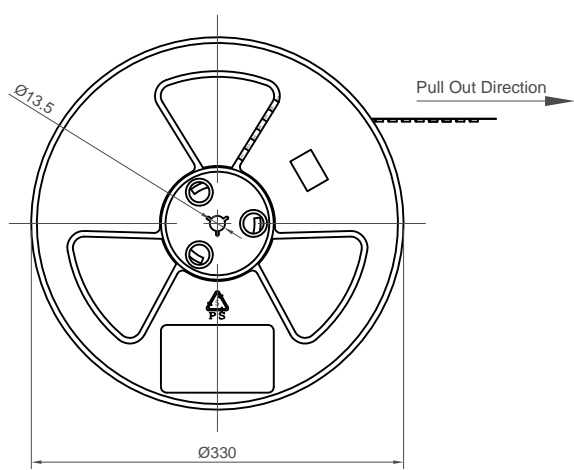
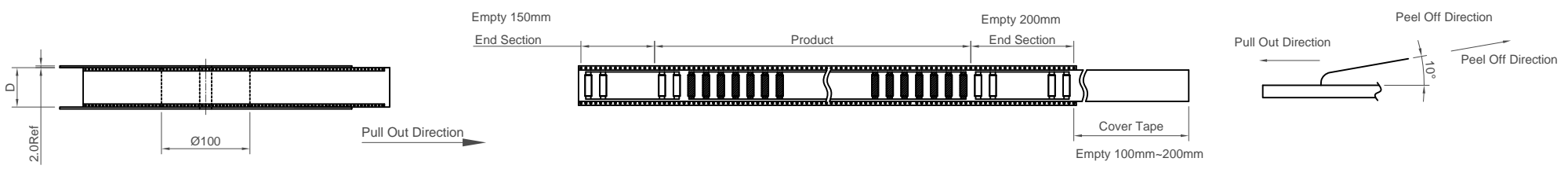

No. of Contacts	Dimensions			
	A	B	C	D
4 ~ 9	7.5±0.20	/	16.0±0.30	16.4±0.30
10 ~ 24	11.5±0.20	/	24.0±0.30	24.4±0.30
25 ~ 34	14.2±0.20	28.4±0.20	32.0±0.30	32.4±0.30
35 ~ 54	20.2±0.25	40.4±0.20	44.0±0.30	44.4±0.30

- NOTES:
- 1.Number of Connectors:
2000 Pcs/Reel
 - 2.Material
Carrier Tape:PET,PE,PEF
Reel:PS
 - 3.Peeling off force of top tape
30gf~130gf

Part Number		Product Description	
FFC2B25		FPC 0.5mm Pitch Side Entry, Bottom Contact, SMT, Height=2.0mm, ZIF, Flip Lock Type	
Drawing Date		29th May 2010	
By	CC	Tolerances (Except as Noted)	Units:
Detail	FFC2B25 D PCN	Length	Metric (mm)
Revision	D1	X.X ± 0.20	
Date	10/12/18	X.XX ± 0.10	
		X.XXX ± 0.05	3rd Angle Projection

GCT
www.gct.co

Not to Scale	Drawn By PKN	Sheet No. 2/2
--------------	--------------	---------------

